

# 3form® POINT SUPPORT™

---



3form® standoff and spider *point-support* systems provide versatile and elegant solutions for affixing 3form materials to a variety of substrates, including wood, concrete, steel studs, gypsum, and aluminum framing systems, such as 3form Versa. An impressive range of precision machined components, including barrels, caps, spiders, and anchors, work together as an integrated solution to provide both flexibility and ease of installation.



---

For more information, please visit [www.3form.eu](http://www.3form.eu) or email [info@3form.eu](mailto:info@3form.eu) or call +31 (0) 88 336 576 00

JANUARY 15<sup>TH</sup> 3form BV, All rights reserved

## OVERVIEW

### SPECIFICATION

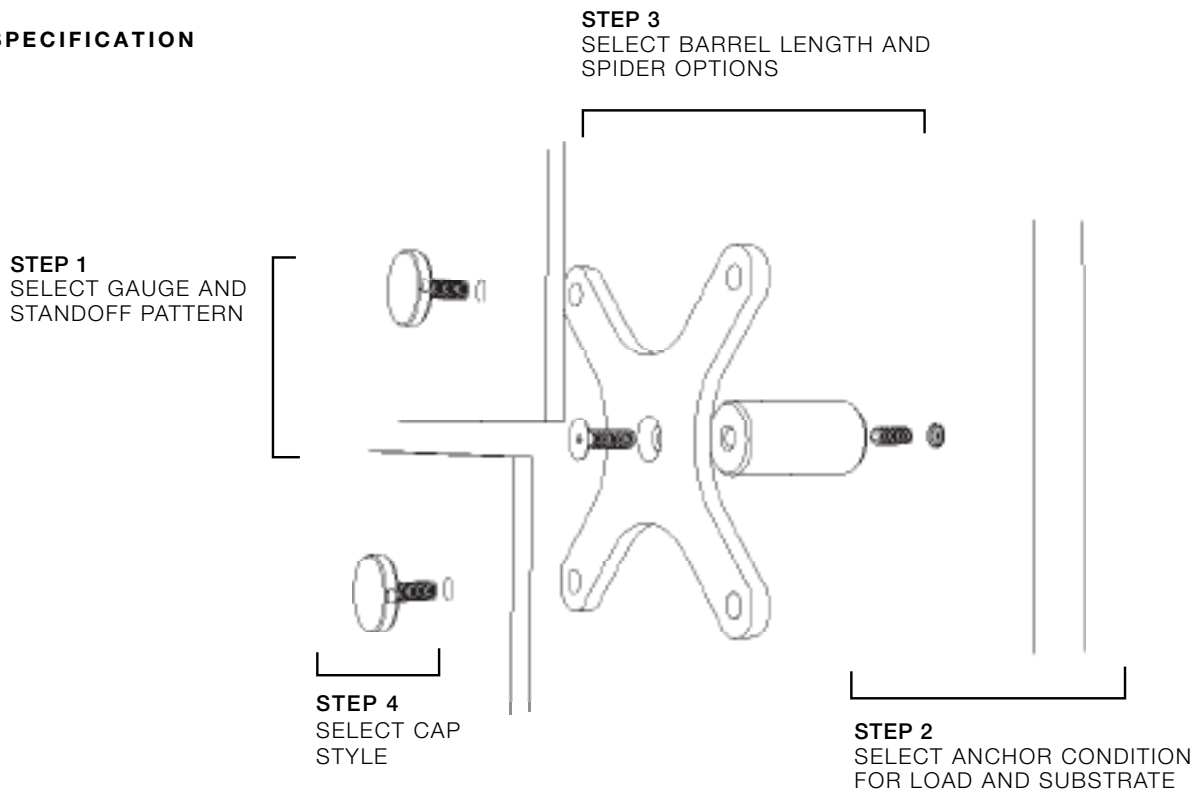

From left to right, the different components that will be specified include the cap, panel gauge and resulting standoff pattern, spider type and/or barrel size, and anchor conditions. The individual components will be presented below, followed by detailed solutions for recommended number of point supports and anchor assemblies.

### GAUGE AND STANDOFF PATTERN

The thicker the gauge of a panel, the fewer point supports that are needed to prevent deflection of the panel, but the greater number of point supports required to distribute the weight. Similarly, the thinner the gauge of a panel, the fewer point supports that are needed to hold the weight of the panel, but more are required to prevent deflection.

## **SUBSTRATE / ANCHOR CONDITIONS**

3form provides support for the following anchor conditions:

- Drywall
- Wood Stud or Blocking
- Metal Stud or Blocking
- Concrete
- Aluminum framing systems, including 3form Versa

The stronger and less compressible the substrate, the greater amount of weight the anchor can bear.

For maximum stability, 3form recommends concrete, wood blocking, or aluminum framing for all standoff system installations. However, drywall and "kitchen sink" blocking solutions are also presented below.

## **BARREL LENGTH**

The longer the selected barrel length, the more force a given load will place upon the anchor and substrate and the greater the load the respective anchor must be able to bear.

## **SPIDER CONNECTION**

The use of a spider, because it may attach to two or more panels, increases the weight and load of a given anchor and subsequently may require the use of additional support points.

## SOLUTIONS

### SOLUTION 1: (5) 1220 X 1220 MM (4' X 4') PANELS ON CONCRETE SUBSTRATE

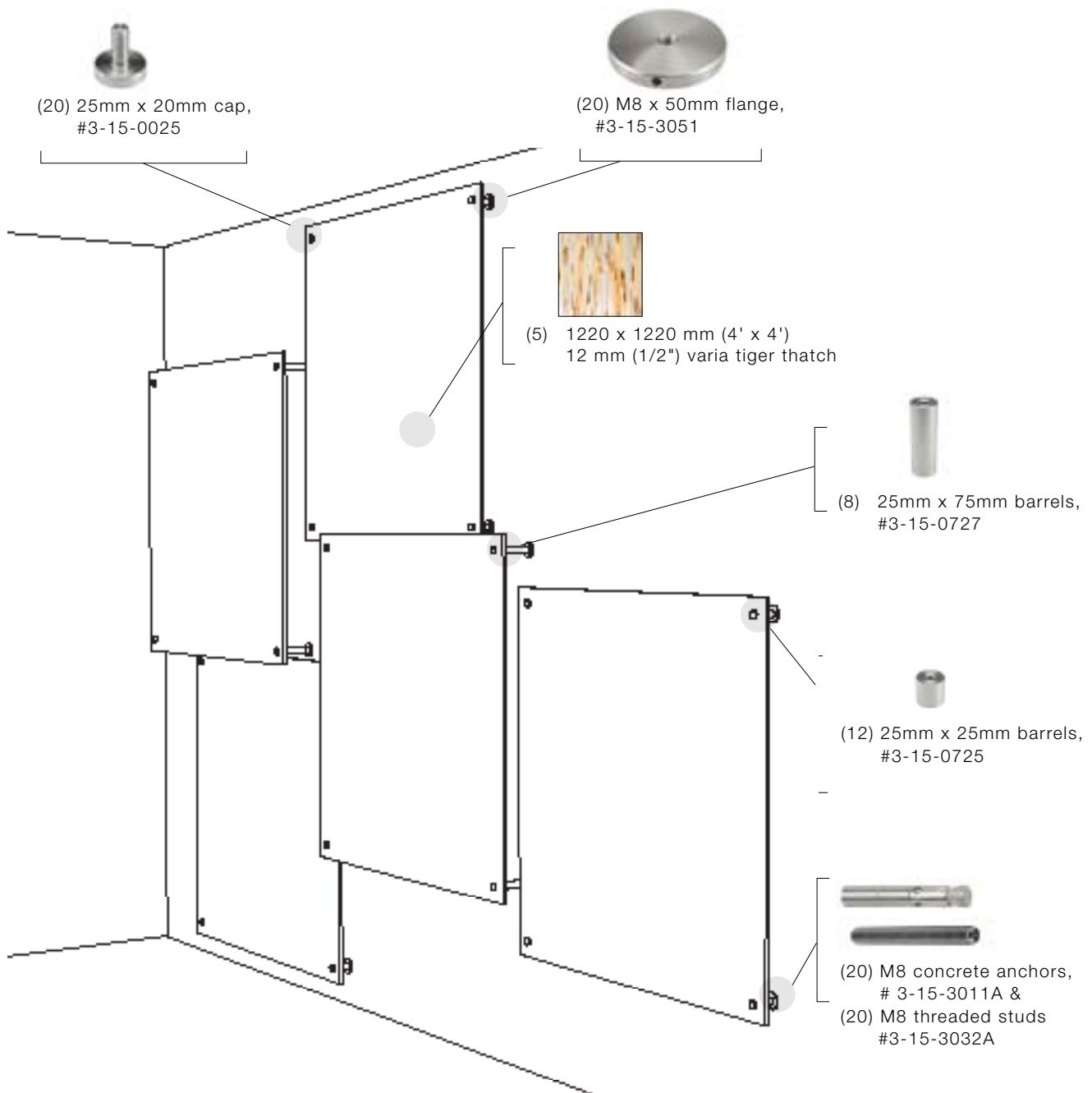

# 3form® POINT SUPPORT™

## SOLUTION 2: (10) 2440 X 610 mm (8' X 2') PANELS ON WOOD SUBSTRATE

In the diagram below, a flange is used against the wall as well as at the end of the barrel for single connection points. Because spiders are being used at the end of the 25 mm (1") barrels for 2 and 4 point connection points, a spacer is used at the end of barrels for single connection points to ensure the connection point is the same distance from the wall for all connections.

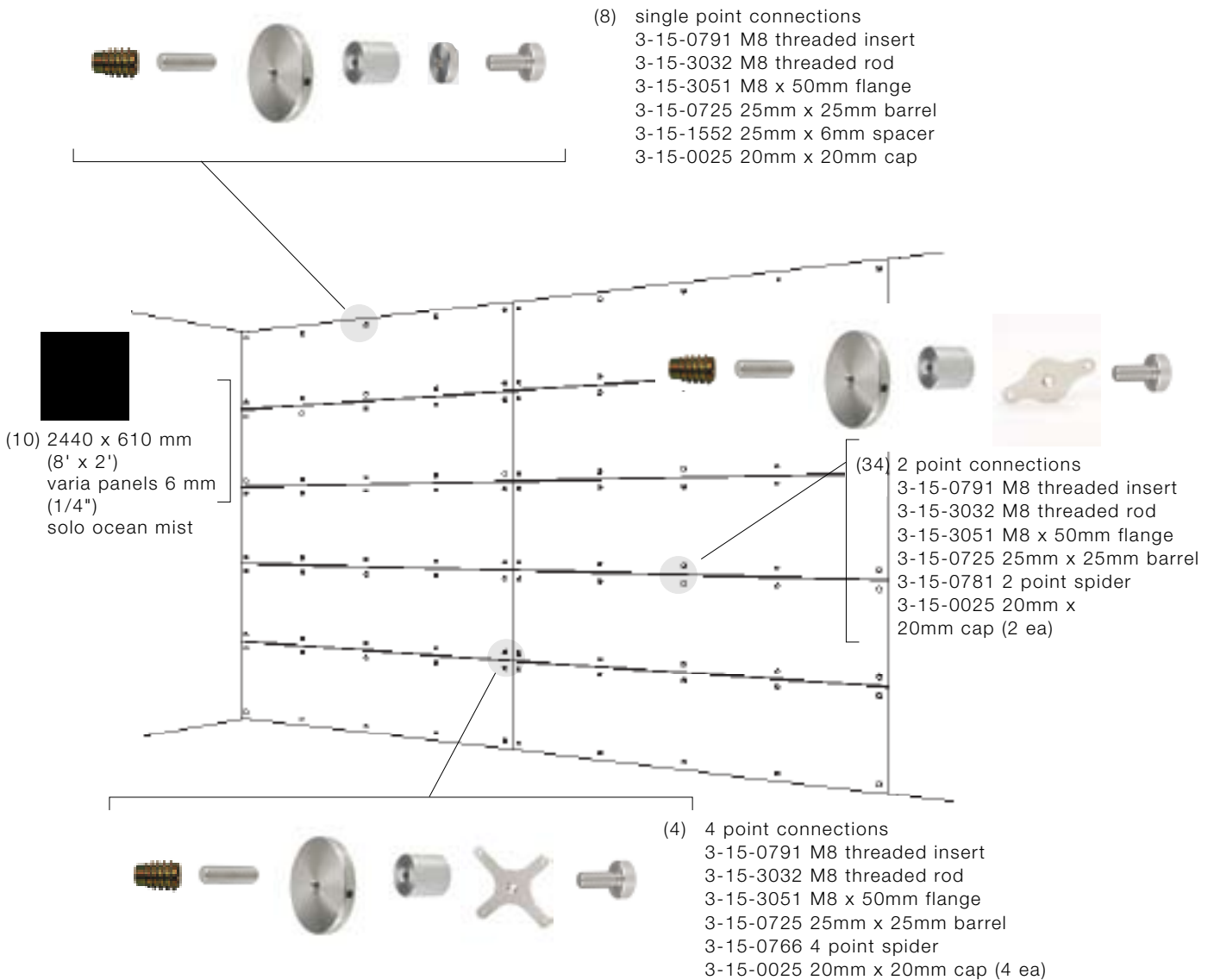

## PANEL GAUGE AND STANDOFF PATTERN

There is a general trade off between panel gauge, stiffness, and the required number of standoffs. The greater the thickness of the panel, the greater the rigidity and stiffness of the panel, but the more it weighs, naturally. Table 1, below, contains the weights of the different gauges of material.

<b>PANEL GAUGE (MM)</b>	1.6	3	5	6	10	12	19	25
<b>PANEL GAUGE, NOMINAL</b>	1/16"	1/8"	3/16"	1/4"	3/8"	1/2"	3/4"	1"
<b>KG/M<sup>2</sup></b>	2,1	4	5,8	7,7	11,5	15,4	23	34,6
<b>K6/PANEL (1220 X 2440 MM)</b>	6,4	11,8	17,2	22,7	34	45	68	90,7

With that in mind, the number of point supports required for a given panel must address both **deflection** and **weight**. For example, a 3 mm x 1220 x 2440 mm (1/8" x 4' x 8') panel requires 15 point supports to prevent visible deflection but only 1 for weight. conversely, a 25 mm x 1220 x 2440 mm (1" x 4' x 8') panel requires 4 point supports to prevent visible deflection, but requires 6 for weight.

3form point support systems have been engineered to address both weight and deflection. Our recommended patterns, found on the next page, assumes the following:

- one panel attachment per point support.
- the top connections bear the full weight of the panel.
- the side and bottom point supports are present to prevent deflection and bowing.
- the use of spiders would alter the number of top point supports required.

Full details considering barrel length, substrate, panel gauge and size, and spider attachments are found later in the document.

## STANDOFF PATTERNS

These standoff patterns take into account both the weight and visible deflection of the different gauges and panel sizes. If the desired panel size is not shown, we suggest using the standoff pattern of the next largest panel size. Certain substrate conditions, barrel lengths, and the use of spiders may require additional point supports.

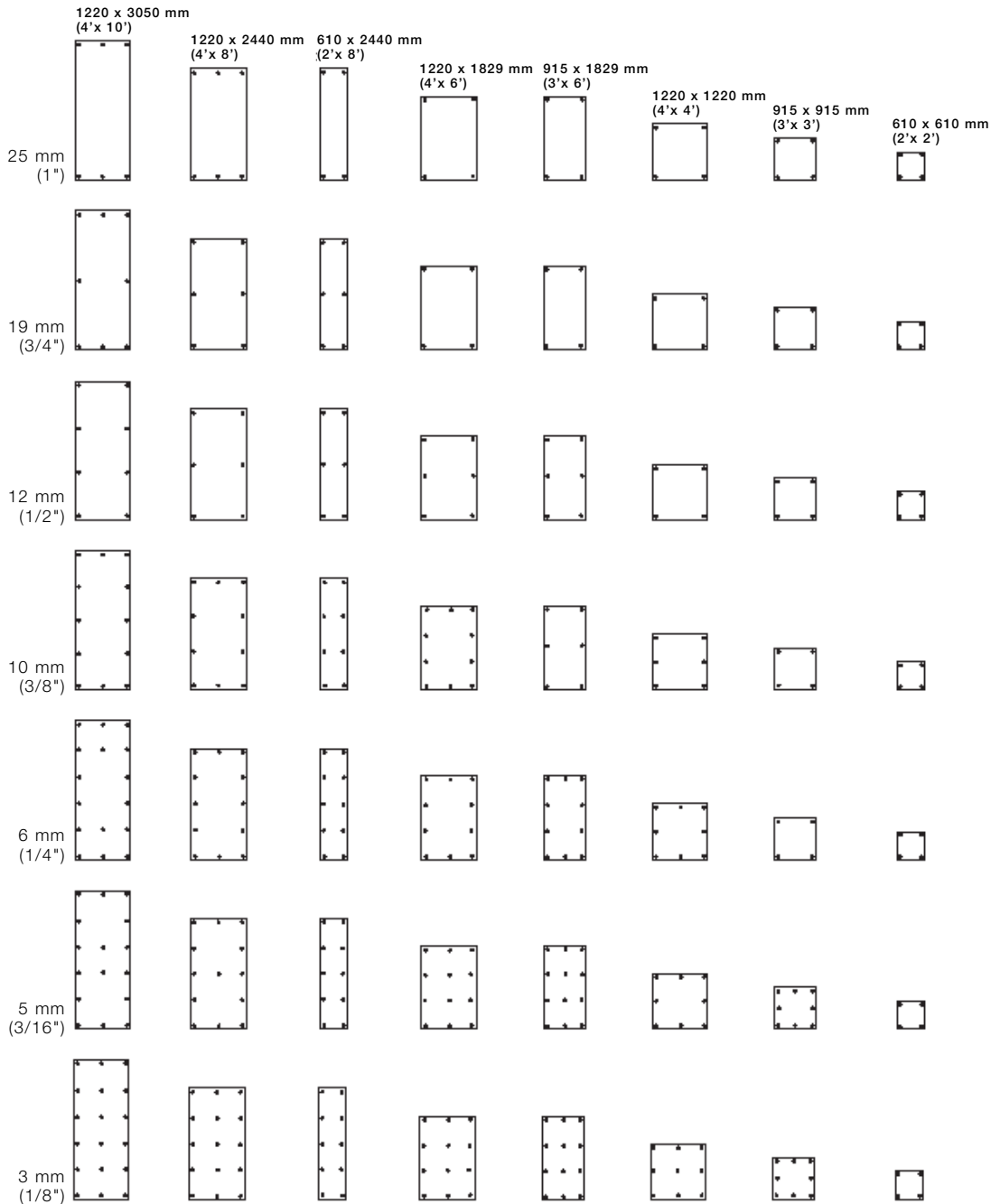

## ANCHOR CONDITIONS

### CONCRETE

The concrete anchor is placed directly into the concrete. The threaded rod is inserted into the anchor. The flange is then threaded onto the rod, flush against the wall.

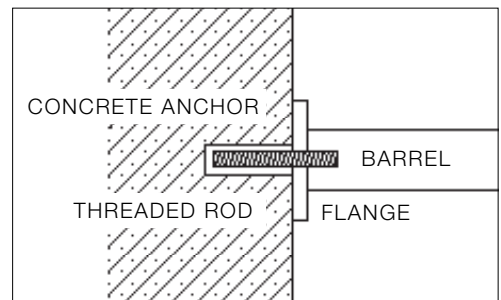

top view

### WOOD

3form offers 2 different options for fastening to a wood substrate, a threaded insert anchor and an external threaded wood anchor. Both are illustrated below. The external threaded anchor has M8 threads on one end upon which the barrel can be fastened directly. The threaded insert requires an additional M8 threaded stud to couple the barrel to the anchor. Both can accept the flange to cover up any pre-drill openings and add support.

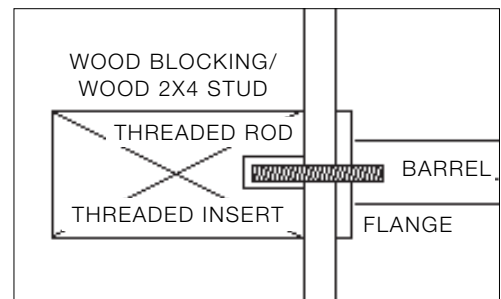

top view

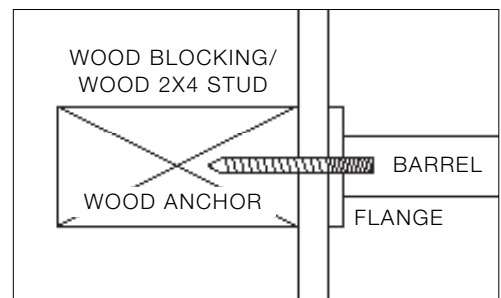

top view

# 3form® POINT SUPPORT™

## HOLLOW WALL

For hollow walls conditions (drywall or sheet metal studs), 3form offers an M8 threaded snap toggle bolt. Similar to the anchor conditions above, the barrel can be fastened secured to the wall via an M8 threaded stud coupling the barrel with the toggle bolt.

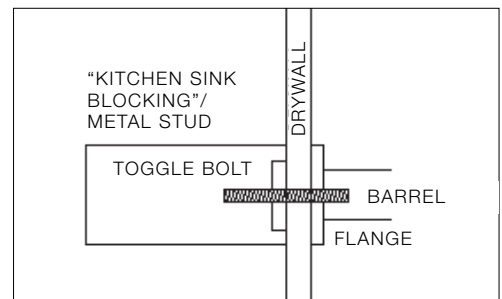

top view

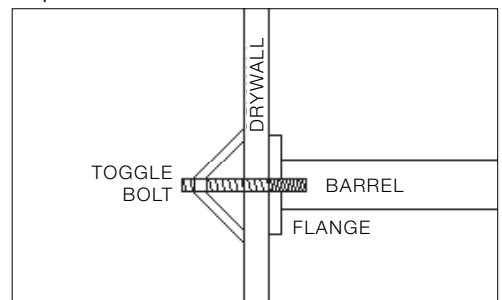

top view

## ALUMINUM FRAMING

3form point supports can also be mounted to aluminum framing structures via a drop-in T-Nut. After inserting the drop in T-Nut into the channel, the threaded rod threads directly into the T-nut, and the barrel directly onto that.

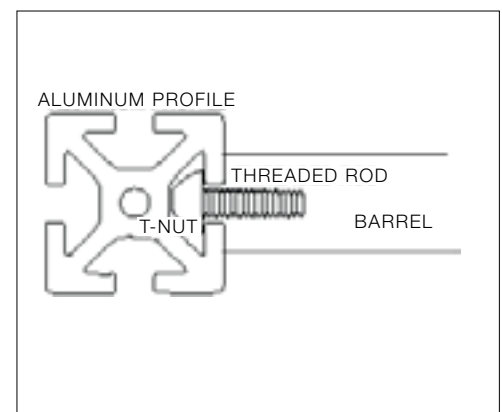

top view

# 3form® POINT SUPPORT™

## 100 MM (4") 4-HOLE MOUNTING PLATE

With its larger surface area and additional wall attachment points, it can support heavier loads for a given substrate. It ships with both 6 mm (1/4")-20 machine screws and #14 wood screws for installation into other drywall or wood studs. Installation diagrams are found below.



### 4 MACHINE SCREWS INTO 12 mm (1/2") HOLES (W/TOGGLE BOLT)

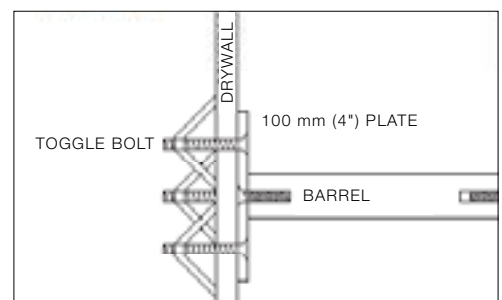

top view

### 2 WOOD SCREWS INTO 4 mm (5/32") PILOT HOLE IN STUD & 2 MACHINE SCREWS INTO 12 mm (1/2") HOLE (W/TOGGLE BOLT)

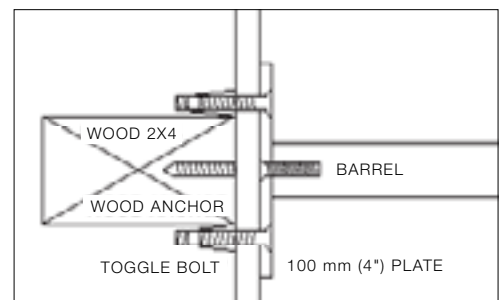
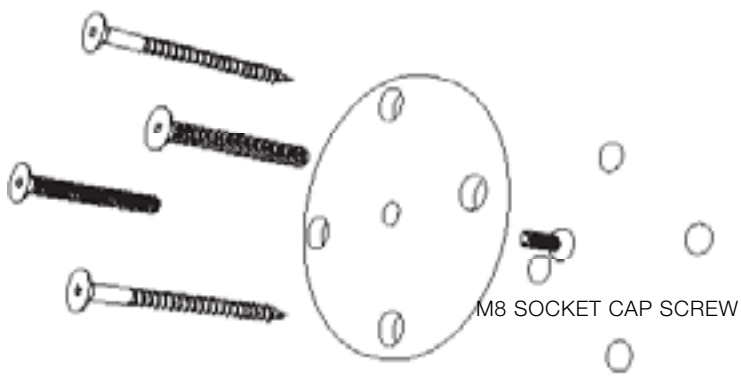

top view

# 3form® POINT SUPPORT™

## 4 BOLT CONNECTOR W/HOLE

The 4 bolt connector is designed to capture and align the edges of supported panels. It works best when arranging a series of small panel sizes (610 x 610 mm / 2' x 2' or approximately). While functionally similar to a spider connection, it provides a different look.

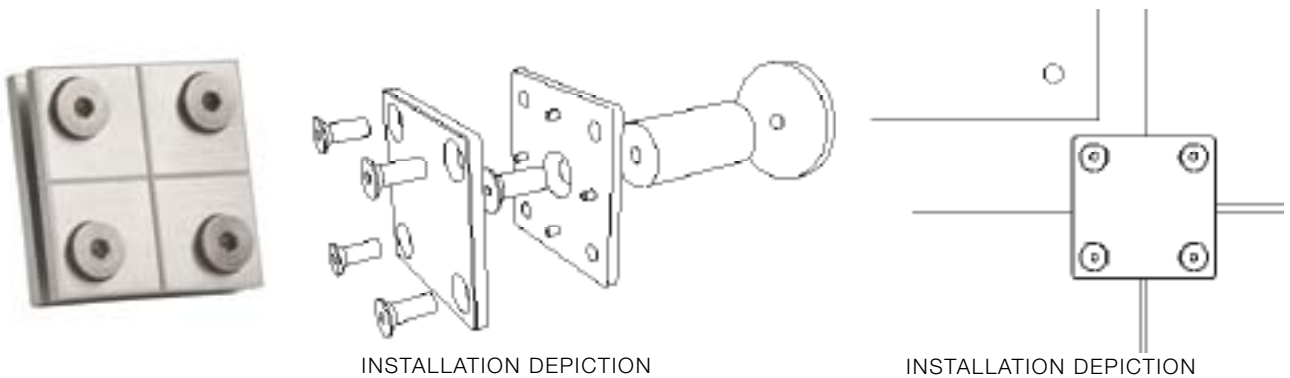

## STANDOFFS WITH GLASS

When using standoffs with glass, care must be made to ensure that there is no metal to glass contact throughout the installation. 3form offers cut to length tubing and washers to protect the glass for these situations. Another consideration when using with glass is that caps should only be hand tightened or the glass may crack over time. Do not use the spanner wrench when placing caps on glass.

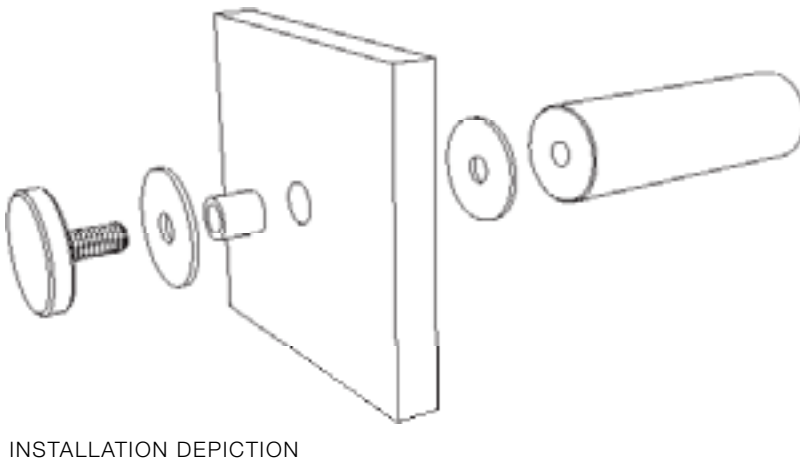

## COMPONENTS

Below are some specifications and dimensions for the primary components involved in the system. Additional instructions on installing the system can be found in the last section of this document.



### BARRELS

PRODUCT ID	3-15-0720	3-15-0721	3-15-0722	3-15-0725	3-15-0726	3-15-0727	3-15-0728	3-15-0729
<b>DIAMETER</b>	20 MM	20 MM	20 MM	25 MM	25 MM	25 MM	25 MM	25 MM
<b>THREADS</b>	M8 THRU	M8 X 19MM	M8 X 19MM	M8 X THRU	M8 X 19MM	M8 X 19MM	M8 X 19MM	M8 X 19MM
<b>LENGTH</b>	25 MM	50 MM	75 MM	25 MM	50 MM	75 MM	100 MM	150 MM
<b>MATERIAL</b>	STAINLESS	STAINLESS	STAINLESS	STAINLESS	STAINLESS	STAINLESS	STAINLESS	STAINLESS

**NOTE** REQUIRES TUBING AND WASHERS WHEN USED WITH GLASS. ALSO, 1/4 IN AND 1/2 IN SPACERS AVAILABLE.



### SPIDERS

PRODUCT ID	3-15-0766	3-15-0767	3-15-0781	3-15-0768
<b>CONNECTIONS</b>	4	2	2	1
<b>SPAN (HOLE CENTER)</b>	100 MM	100 MM	100 MM	100 MM
<b>ARM LENGTH</b>	70 MM	70 MM	70 MM	70 MM
<b>THICKNESS</b>	6 MM (1/4 IN)	6 MM (1/4 IN)	6 MM (1/4 IN)	6 MM (1/4 IN)
<b>MATERIAL</b>	ALUMINUM	ALUMINUM	ALUMINUM	ALUMINUM
<b>INCLUDES</b>	COUNTERSUNK FASTENER AND LOCATING PIN			



### CAPS (STANDARD)

PRODUCT ID	3-15-0020	3-15-0025	3-15-0026	3-15-0027	3-15-0028	3-15-0029
<b>DIAMETER</b>	20MM	25MM	25MM	25MM	25MM	25MM
<b>THREADS</b>	M8 X 20MM	M8 X 20MM	M8 X 17MM	M8 X 10MM	M8 X 25MM	M8 X 32MM
<b>CAP DEPTH</b>	5 MM (3/16 IN)	5 MM (3/16 IN)	5 MM (3/16 IN)	5 MM (3/16 IN)	5 MM (3/16 IN)	5 MM (3/16 IN)
<b>MATERIAL</b>	STAINLESS	STAINLESS	STAINLESS	STAINLESS	STAINLESS	STAINLESS

# 3form<sup>®</sup> POINT SUPPORT™



## CAPS (COUNTERSUNK)

	3-15-0736	3-15-0737	3-15-0738	3-15-0739	3-15-0740
<b>PRODUCT ID</b>	3-15-0736	3-15-0737	3-15-0738	3-15-0739	3-15-0740
<b>DIAMETER</b>	25 MM	25 MM	25 MM	25 MM	25 MM
<b>THREADS</b>	M8 X 20 MM	M8 X 17 MM	M8 X 10 MM	M8 X 25 MM	M8 X 32 MM
<b>ANGLE</b>	82 DEG	82 DEG	82 DEG	82 DEG	82 DEG
<b>MATERIAL</b>	STAINLESS	STAINLESS	STAINLESS	STAINLESS	STAINLESS



## 4 BOLT CONNECTOR W/HOLE

<b>PRODUCT ID</b>	3-15-1511
<b>WIDTH</b>	50 MM (2 IN)
<b>HEIGHT</b>	50 MM (2 IN)
<b>GAUGE</b>	3 MM TO 12 MM (1/8 IN TO 1/2 IN)
<b>INCLUDES</b>	4 FASTENERS



## 4 HOLE MOUNTING PLATE

<b>PRODUCT ID</b>	3-15-0733
<b>DIAMETER</b>	100 MM (4 IN)
<b>INCLUDES</b>	(4) 1/4-20 MACHINE SCREWS (4) #14 WOOD SCREWS (1) M8 COUNTERSUNK SCREW
<b>PRE-DRILL</b>	12 MM (1/2 IN) FOR 1/4-20 TOGGLE BOLTS 4 MM (5/32 IN) FOR #14 WOOD SCREWS
<b>MATERIAL</b>	STAINLESS



## FLANGE

<b>PRODUCT ID</b>	3-15-3051
<b>DIAMETER</b>	50 MM (2 IN)
<b>THREADS</b>	M8
<b>THICKNESS</b>	6 MM (1/4 IN)
<b>MATERIAL</b>	STAINLESS

# 3form® POINT SUPPORT™



## SPACERS

	3-15-1543	3-151544	3-15-1552	3-15-1553
<b>PART ID</b>	3-15-1543	3-151544	3-15-1552	3-15-1553
<b>DIAMETER</b>	19 MM (3/4 IN)	19 MM (3/4 IN)	25 MM (1 IN)	25 MM (1 IN)
<b>LENGTH</b>	6 MM (1/4 IN)	12 MM (1/2 IN)	6 MM (1/4 IN)	12 MM (1/2 IN)
<b>MATERIAL</b>	STAINLESS	STAINLESS	STAINLESS	STAINLESS

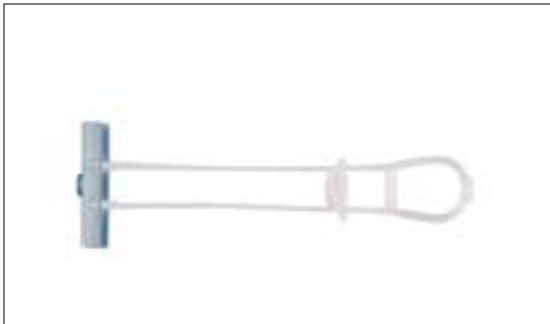

## TOGGLE BOLT

	3-15-0734	3-15-0735
<b>PRODUCT ID</b>	3-15-0734	3-15-0735
<b>THREADS</b>	M8	1/4 - 20
<b>PRE-DRILL</b>	19 MM (3/4 IN)	12 MM (1/2 IN)
<b>MIN DRY WALL THICKNESS</b>	10 MM (3/8 IN)	10 MM (3/8 IN)



## CONCRETE ANCHOR

<b>PRODUCT ID</b>	3-15-3011A
<b>DIMENSIONS</b>	10 MM X 50 MM (3/8 IN X 2 IN)
<b>INTERNAL THREADS</b>	M8 X 15 MM (M8 X 5/8 IN)
<b>MIN CONCRETE THICKNESS</b>	150 MM (6 IN)
<b>PRE-DRILL</b>	10 MM X 65 MM (3/8 IN X 2 1/2 IN)
<b>MAX LOAD</b>	1000 LB-FORCE



## THREADED INSERT (FOR WOOD)

<b>PRODUCT ID</b>	3-15-0791
<b>LENGTH</b>	20 MM (3/4 IN)
<b>INTERNAL THREADS</b>	M8 THRU
<b>PRE-DRILL</b>	10 MM X 20 MM (3/8 IN X 3/4 IN)

# 3form<sup>®</sup> POINT SUPPORT™



## WOOD ANCHOR

<b>PRODUCT ID</b>	3-15-3001	3-15-3002
<b>LAG LENGTH</b>	38 MM	38 MM
<b>THREAD LENGTH</b>	M8 X 12 MM (M8 X 1/2 IN)	M8 X 22 MM (M8 X 7/8 IN)
<b>PRE-DRILL</b>	4 MM (5/32 IN)	4 MM (5/32 IN)



## THREADED STUD

<b>PRODUCT ID</b>	3-15-3032	3-15-3033	3-15-3032A	3-15-3033A
<b>THREADS</b>	M8 X 30 MM M8 X 1.18 IN	M8 X 40 MM M8 X 1.57 IN	M8 X 50 MM M8 X 2 IN	M8 X 60 MM M8 X 2.36 IN
<b>MATERIAL</b>	STAINLESS	STAINLESS	STAINLESS	STAINLESS



## GLASS ACCESSORIES

<b>PRODUCT ID</b>	3-15-1102	3-15-1004	3-15-1003
<b>DESCRIPTION</b>	19 MM (3/4") TEFLON WASHER	TUBING CUTTER	8 MM (5/16") ID X 14 MM (9/16") OD TUBING